

# Advice on Mounting blocks on routes used by equestrians

**The law and management of public access rights vary widely between the four countries of the United Kingdom. Practical elements of the following advice apply in all countries but the legal requirements in Scotland and Northern Ireland may differ from those in England and Wales.**

More advice is available on [bhs.org.uk/accessadvice](https://bhs.org.uk/accessadvice).

**IMPORTANT** This guidance is general and does not aim to cover every variation in circumstances. Where it is being relied upon, The Society recommends seeking advice specific to the site.

This advice is for mounting blocks on bridleways, byways and other public routes used by equestrians. It does not attempt to cover equestrian premises or events where needs may differ.

Position of Mounting Blocks .....	2
Large Mounting Blocks .....	3
Specification .....	3
Small Mounting Blocks .....	4
People with limited mobility .....	5

A rider usually has most control of a horse while mounted by using the rider's seat, legs and hands. When leading a horse and while mounting or dismounting, control is reduced because the first two means are removed and the last is compromised.

During mounting or dismounting, a rider is at particular risk of any movement of the horse arising from that reduced control. A sudden move, such as from the horse being startled, can result in serious injury to the rider as falling is the most likely outcome.

The risk in mounting or dismounting may be further raised by the rider's age, agility, relative size to the horse or a disability. The risk can also be raised by the horse's temperament and whether it has just been distressed or by the sensitivity of its back.

Mounting from the ground is not recommended because of the strain it puts on the horse and a saddle, potentially causing injury or damage which is costly to rectify, perhaps requiring veterinary assistance and weeks off work, as well as pain and suffering for the animal. It may also cause injury to the rider or pain from common health conditions such as arthritis.

Riders lower the risk of mounting by raising themselves in relation to the horse, ideally using a sturdy mounting block. This greatly reduces the effort required to reach the horse's back and

the time taken, so gaining control quickly, and reduces the strain on the horse, saddle and rider.

Use of a mounting block is automatic for many riders at the start of a ride and some riders are not able to mount without being raised even though they are able to ride for miles once mounted. They may also be unable to walk far. A situation which forces riders to dismount while out riding may mean they have to find a means to raise themselves to remount and may prevent some riders from using that route.

Situations which force a rider to dismount should therefore be avoided if possible, but where there is no alternative, a mounting block should be provided to increase the safety of both horse and rider. Typical examples include a bridge which has parapets below ideal height or an underpass which cannot be raised.

Whether to dismount at an obstruction should be left to a rider's discretion. They will know their own and their horse's limits and whether, given the hazard before them, they will actually be safer remaining mounted or dismounting. Riders will generally be risk-averse because they are considering their horse as well as themselves.

Mounting blocks will also be welcomed at car parks where horsebox parking is permitted and at a picnic place, shop, café or toilets where riders may dismount to use the facilities.

## Position of Mounting Blocks

The siting of a mounting block needs to consider the space available and the proximity of the situation which has caused the rider to dismount.

Riders will most commonly mount from the left side of the horse so a mounting block should be sited:

- To the **near** side of the natural line of travel **after** the obstruction where horse and rider can easily access the mounting block
- Easily visible so that a rider unfamiliar with the area can see there is a means of remounting
- With firm level ground for the horse next to the mounting block away from gratings and overhanging vegetation and with adequate manoeuvring space to come alongside the mounting block
- With equal clear space before and after the point at which the rider will stand to mount as a horse's saddle will be about halfway along its length (average 2.4m long from nose to tail)

If a mounting block is installed after a bridge crossing a busy road or railway, it should be sited at a distance such that the horse is less likely to be disturbed by the hazard while the rider mounts. The distance will vary depending on the site, screening (e.g. by trees) and

environment and may be best assessed with the help of the local BHS Access Officer. It is likely to be a few metres beyond the traffic flow.

For a less disturbing situation such as a watercourse bridge or an underpass without heavy traffic, the mounting block may be sited close to the obstruction, so long as it does not interfere with the manoeuvring space required for either the obstruction or the mounting block.

## Large Mounting Blocks

### Specification

- Step height 240mm to 260mm
- Total height up to 780mm
- Width minimum 600mm
- Step length minimum 450mm
- Top platform length minimum 750mm

It is recommended that steps are provided at both ends of the central platform so that if a horse walks forward, the rider can go down the steps rather than have to jump off a high platform.

Clear manoeuvring space 3.7m high and at least 1.8m wide to the right side of the mounting block extending at least 3m before and beyond the mounting block.

The material forming the steps and platform should be of a non-slip nature.

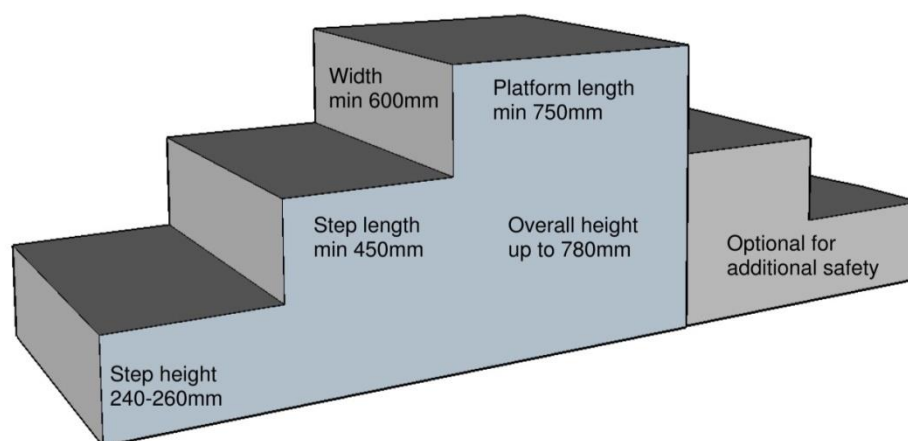

Figure 1 Side view of a mounting block

Figure 1 illustrates a mounting block with steps at both ends of the top platform. It is designed to have the horse on the off side of the mounting block, between the mounting block and the viewer. Riders would walk up the steps with a horse to their right and mount from the horse's left side. If the horse should walk forward before the rider has mounted, the rider is able to

descend using the additional steps rather than jumping off the top platform. If space does not permit, then the additional steps can be omitted.

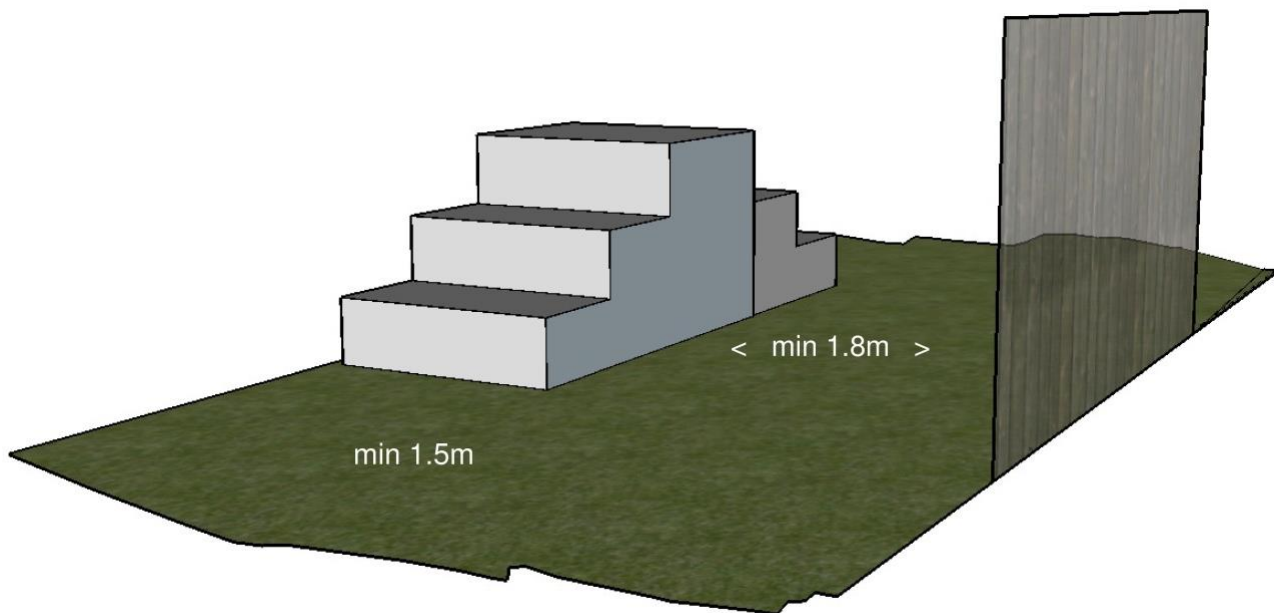

Figure 2 Mounting block with manoeuvring space

The manoeuvring space also needs to be on the off side of the mounting block as Figure 2.

The manoeuvring space is shown for illustrative purposes between the mounting block and a fence as 1.8m is the minimum space required between the mounting block and another structure. A fence is not a requirement.

The total length of the manoeuvring space is 3m more than the length of the mounting block, 1.5m at each end to allow space for the horse to approach so as to be parallel to the mounting block, and to leave the space by moving forwards.

## Small Mounting Blocks

The specification above is the ideal but there are many situations where such a construction is not reasonable or practical, perhaps due to constraints of space or distance to transport materials. Equality Act principles apply in terms of what is reasonable in the situation. Where the structure that forces a rider to dismount is in a populated area, well-used by riders of all abilities, including those who may have restricted mobility, the specification will be higher than in a more remote location where use is lower and a rider is more likely to have reasonable mobility to have reached it (remembering that once mounted, people with impaired agility may be able to ride highly demanding terrain for long distances but mounting or dismounting may be difficult). The level of specification should always be considered in terms of the context and local environment and where necessary the advice of the BHS should be sought for a specific site.

Many common items are feasible as mounting blocks including flattened logs, tree stumps, building blocks, a reinforced bank, stone step stile: endless possibilities depending on the site.

The primary requirement for safety is for the block to be stable, ideally fairly level and with a non-slip surface.

It requires space to manoeuvre and for the horse to stand with its near side to the block.

The top should be large enough for both of the rider's feet parallel to and alongside the horse.

Level ground is needed next to the block for the horse to stand on close to the rider so, for example, a tree stump may seem ideal but the slope of the base of the stump and tree roots may place the horse a metre or more away from the rider, which is not much help.

For a single block of whatever material, the maximum height is about 500mm for most people to be able to step onto it easily. Toeholds are often easily made and can help immensely, bearing in mind that they need to be large enough to accommodate boots.

A simple design, which can be transported and built anywhere if there is nothing suitable on site uses a 700mm length of 350-450mm plastic drainpipe (commonly twin wall corrugated type) which is stood on end and embedded by 200mm, then filled with any material on site (a mixture of stone and earth) then rammed firmly to compact it and topped with 30mm concrete or cement cap, shaped sufficiently convex or sloping to shed water. A hole half way up to create a toe hold may be welcome. The plastic will degrade in light so is best situated out of direct sunlight for a longer life. More concrete can be included round the edge of the fill so that degradation of the plastic does not affect the integrity of the structure, or the contents can be mixed with cement and some water so that it hardens to form an impervious structure.

## People with limited mobility

Some sites may make provision for equestrians who need assistance to mount or cannot manage steps to a mounting block. In this case the recommendation from Riding for the Disabled<sup>1</sup> is for a ramp to a platform; the platform being at least 1.2m square, with rails on the two sides opposite the ramp and the horse, as Figure 3.

The standard for a ramp for wheelchair access is 1:12, which is likely to be impractical at most sites. A steeper ramp may still be accessible by some with enough assistance, and preferred over steps as removing a trip hazard.

Ideally, the side opposite the ramp would have steps down closest to the horse's position, as Figure 3, for an assistant to descend while maintaining contact with horse and rider (or where mounting has been aborted). If no steps, the rail would extend along the whole side of the platform.

---

<sup>1</sup> <https://rda.org.uk/>

Note that Figure 3 does not attempt to cover situations requiring a hoist or a platform high enough for direct transition from a wheelchair to saddle. The concept provides only for non-stepped access for someone requiring some support and assistance above ground level.

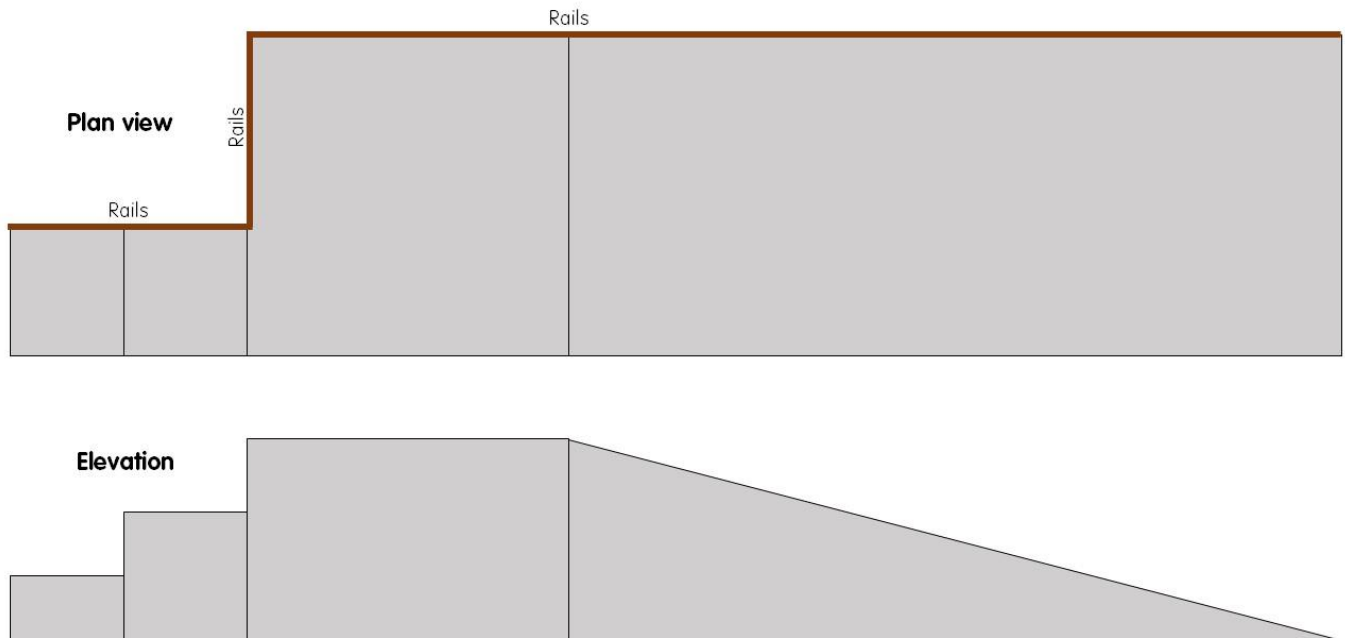

Figure 3 Ramped mounting block concept

N.B. Ramp as illustrated is not to wheelchair accessibility standard

---

If this is a saved or printed copy, please check [bhs.org.uk/accessadvice](https://bhs.org.uk/accessadvice) for the latest version (date top of page 2).